

# Vrtací hlavička

## CNC-Drill chucks



s vnějším chlazením

with coolant supply via spray nozzles

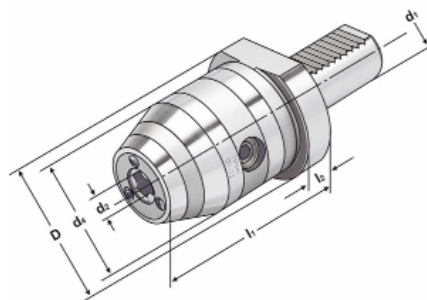

Název Catalog number	$d_1$	Rozsah Capacity	$d_4$	D	$l_1$	$l_2$
VDI16.VK.10	16	1 - 13	57	40	87	5
VDI20.VK.10	20	1 - 13	57	50	87	5
VDI25.VK.13	25	1 - 13	57	58	87	15
VDI30.VK.13	30	1 - 13	57	68	87	22
VDI30.VK.16	30	2,5 - 16	57	68	92	22
VDI40.VK.13	40	1 - 13	57	83	87	22
VDI40.VK.16	40	2,5 - 16	57	83	92	22
VDI50.VK.16	50	2,5 - 16	57	98	96,9	20

dodávka: bez montážního klíče

delivery: without wrench